

Criminal Defense- Based Forensic Social Work

Maren Willins, LCSW , Simmie Baer, Attorney at Law, & Molly Hennessey, LICSW



NOTICE: This project was supported by Grant #2020-ZE-BX-0004 awarded by the Office of Juvenile Justice and Delinquency Prevention, Office of Justice Programs, U.S. Department of Justice. The opinions, findings, and conclusions or recommendations expressed in this program are those of the author(s) and do not necessarily reflect those of the Department of Justice.

What do we DO?



What my friends think I do.



What my significant other thinks I do.



What my mom thinks I do.



What society thinks I do.



What my supervisor thinks I do.



What my clients think I do.



What the State wants me to do.



What I think I do.



What I actually do.



What is Criminal Defense-Based Social Work?

Simply put....

Meeting a client's legal needs and social work needs

Working together

Best legal outcome

Holistic defense

SKILLS

Rapport Building

Assessment

Re-entry

Support

Advocacy

Resource
Identification

Psychoeducation

Clinical
interviewing

Crisis
intervention

Skill building

DIVO

Testifying

Research

MITIGATION!

WORK PRODUCT

Visit Notes

Records Review

Court Reports (Mitigation & Sentencing)

Bio-pyscho-social reports

Memos

Genograms

Eco-maps

Time-lines

Testimony

Eco-map example

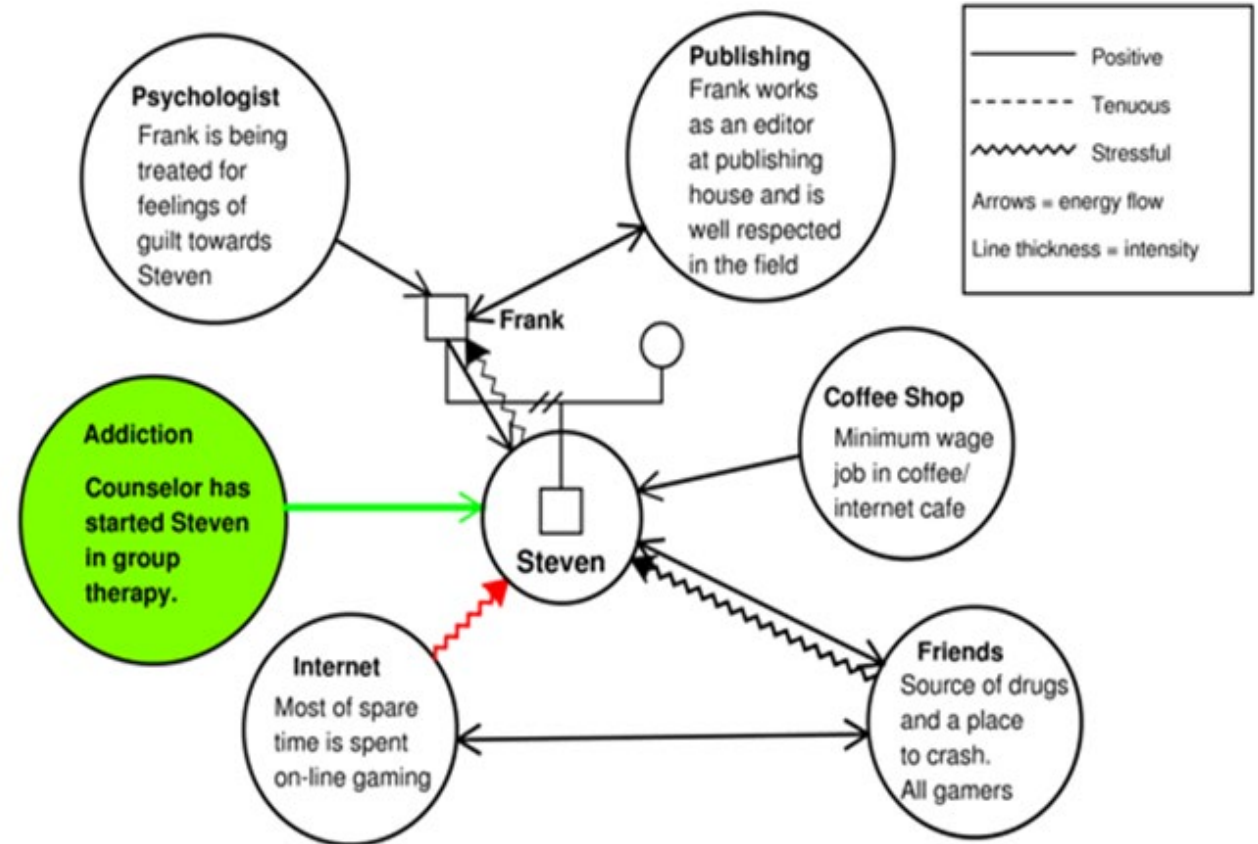

INCARCERATION OF PARENT (12 HOMES, 31 POLICE CONTACT)

30 days jail (8/06)

30 days EHM (2/11)

27 days jail (7/12)

Grandma has guardianship (2014)

3 years DOC (1/05)

120 days jail (8/12)

10 days jail (2/17)

20 days jail (4/02)

3 years DOC (3/05)

90 days jail (9/12)

30 days jail (8/15)

4 days jail (7/17)

2 years + 18-mos Comm Cor (2007-2009)

120 days jail + 90 days + 10 days (2014-2015)

1999 2001 2003 2005 2007 2009 2011 2013 2015 2017

Birth 2 4 6 8 10 12 14 16 18

CLIENT

MOM, GRMA, DAD, GRPA

☐ Transgender Man to Woman

Jamie's Family

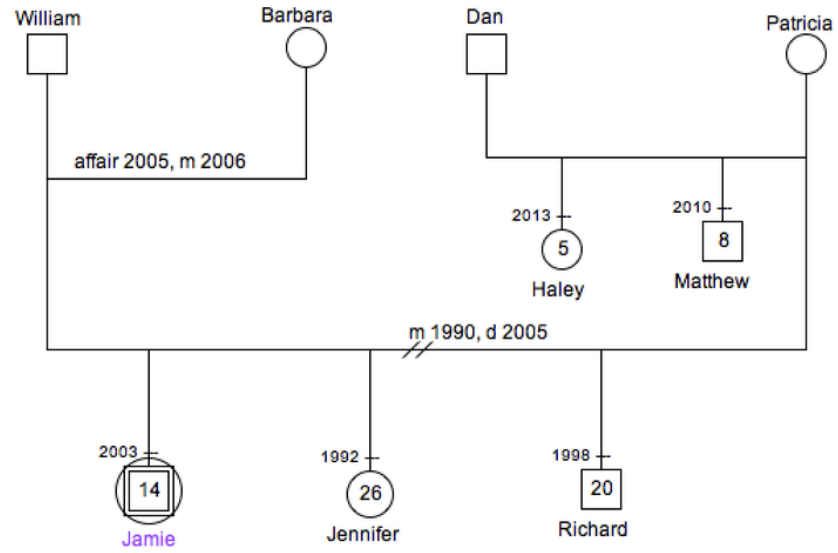

GENOGRAM

ROLES

- Advocacy
- Service referral & navigator
- Assessment
- Mitigation specialist
- Expert
- Researcher
- Re-entry planner
- Therapeutic supporter
- Liaison
- Consultant

If you ever wanna know
what a social worker's
mind feels
like...imagine a
browser with 2, 857
tabs open. All. The.
Time.



someecards
user card

History of CDBFSW

- *-Social Work has always served vulnerable populations*
 - 1963 - *Gideon v. Wainwright* – prompted the systematic creation of public defense systems to serve indigent individuals
 - 1967 – Right to counsel for juveniles
 - 1990 – Fear of the “super predator”, summer of violence
 - 2005 – *Roper v Simmons* - developmental factors, peer influence, identity
 - 2011 – *Miller v Alabama* – *critical differences b/w adult and juvenile brain*
 - 2016 – *Graham v Florida* – *JLWop unconstitutional*
 - Steinberg* – *a leading researcher on adolescence*
 - Colorado model (JLWop, juveniles, direct-file, reverse-transfer)... all CDBFSW clients*
- 2019 - Criminal Defense-Based Forensic Social Work (Ratliff & Willins)

Developmental & Trauma Research

- Dr. Laurence Steinberg <https://www.laurencesteinberg.com/> “Age of Opportunity” & “Adolescence”
- The Gault Center - <https://www.defendyouthrights.org/>
- Hayward-Burns Institute - <https://burnsinstitute.org/who-we-are/#mission>
- Abigail Baird <https://www.vassar.edu/faculty/abbaird> (watch her videos)
- 2011 National Geographic article – <https://www.linkedin.com/pulse/teenage-brain-survival-guide-raise-young-adults-shravan-shetty/>
- Marty Beyers - <https://www.martybeyers.com/content/biography-marty-beyer-phd>
- Bessel Van der Kolk – The Body Keeps the Score
- Center on the Developing Child: Harvard University <https://developingchild.harvard.edu/>
- Traumatic Stress - <https://www.nctsn.org/what-is-child-trauma>

WHY??????

“Each of us is more than
the worst thing that
we’ve ever done.”

-Bryan Stevenson



POLICIES



Federal Guidelines (NASW/NOFSW)



State Guidelines



Agency Guidelines

Requesting records

- A tedious task, but SO important and worth it
- Integral tool for developing and backing up your mitigation/themes
- Can be used as a visual aid in reports
- Experts typically require comprehensive records



Common Sources of Records

- Birth records
 - These typically require the mother's consent
- Medical: pediatrician, psychiatric hospitals, emergency room, etc.
- Child Welfare
- Education
 - Request the student file from the last school attended
 - Special education: IEP and 504 documents come from the district
- DSHS
 - Department of Developmental Disabilities (DDA)
 - State children's psych hospitals (ex: CSTC)
- Mental Health records
- Juvenile Justice related
 - Youth detention records
 - Juvenile probation

Washington Practice Tips

- Health Care authority: if your client is not a good historian, you can request a “health care ledger” that will give you a list of places state Medicaid was billed. For example, hospitals, ERs, community mental health agencies, etc.
- Department of Children Youth & Families (DCYF): statewide system (also how you request records from Juvenile Rehabilitation). These records are extremely slow and take 6+ months to receive
- Practice tips:
 - DCYF requires a client ID be submitted along with the ROI. In lieu of ID, DCYF will take alternative forms. - You can let them know your client is in custody and unable to provide ID, and write a declaration, submit a jail booking photo, or write a letter of representation and attach the notice of appearance.
 - Try to be specific as possible. The narrower the request, the quicker you will get records
 - If you do not need the complete CPS file, you can ask for a “prior involvement report.” This will give an overview of involvement and investigations, but is no where a complete record. Best used in time crunch scenarios

Past, Present,
Future
approach to
each case

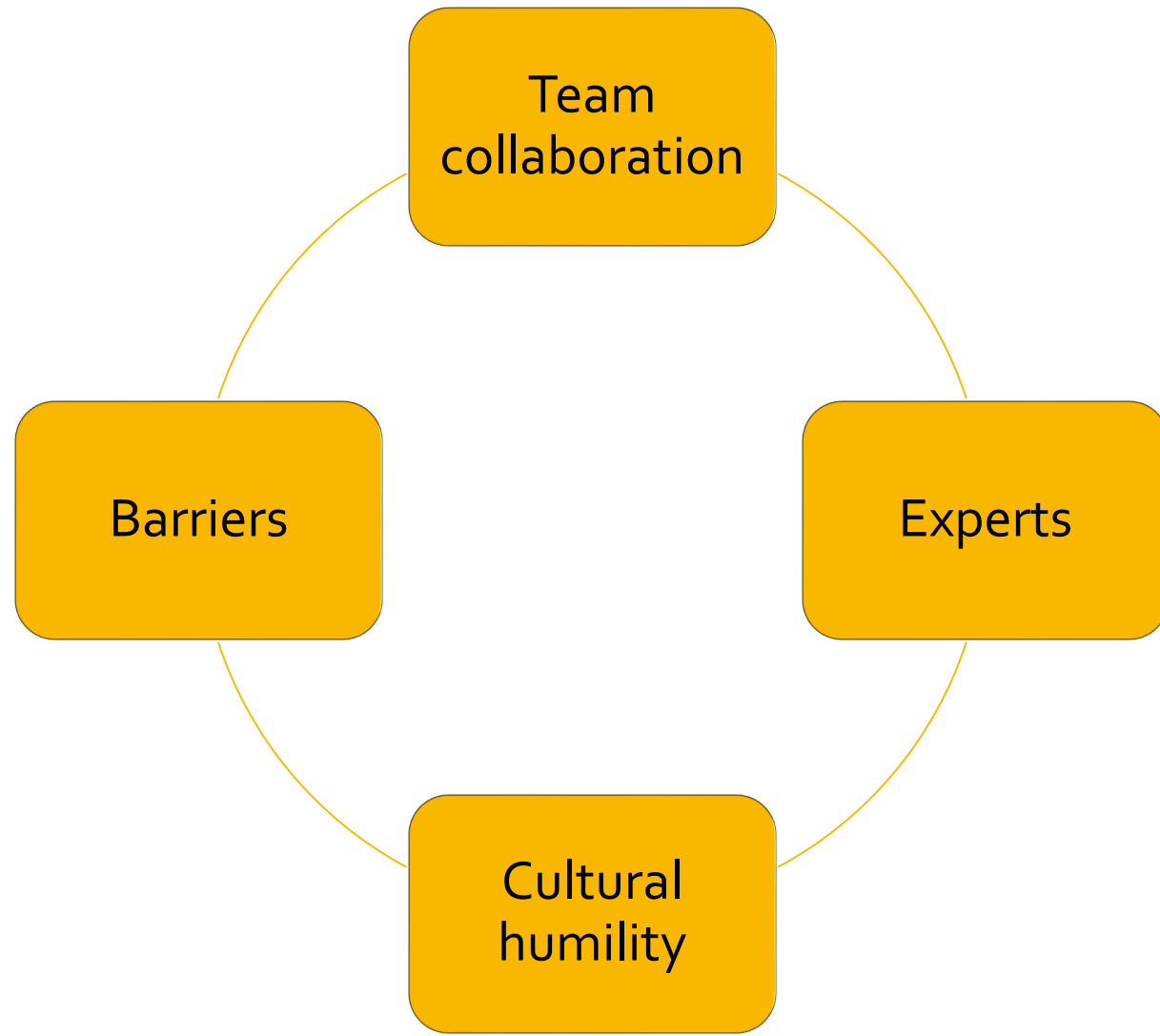

Ethical Conflicts



1.) Anticipate that they WILL happen



2.) Know/Develop a Protocol



3.) Consultation

Protocol Example

- 1.) Team Meeting & Consultation
- 2.) Agency Handbook
- 3.) Supervision
- 4.) Workshop (peer review)



Common Ethical Dilemmas

Harm to self

Harm to others

Child Abuse

Triangulation

Manipulation

Unprofessionalism

Sexual misconduct

Client's free will

Involving the media

Questions?

Thank you! –Maren Willins,
LCSW, Simmie Baer, JD & Molly
Hennessey, LICSW

“NOTICE: This project was supported by Grant #2020-ZE-BX-0004 awarded by the Office of Juvenile Justice and Delinquency Prevention, Office of Justice Programs, U.S. Department of Justice. The opinions, findings, and conclusions or recommendations expressed in this program are those of the author(s) and do not necessarily reflect those of the Department of Justice.”